

# LUNAPRESS®

**LN-600R**  
**LN-900R**

## 氣壓全自動連續式粘襯機 STRAIGHT LINEAR FUSING PRESS



LN-600R Return Type  
LN-900R High Pressure Return Type

### Features

- Continuous fusing system increases productivity with unlimited working length.
- Automatic tracking adjustment device prevents upper and lower belts from snaking and always keeps the belts right in the center position.
- Dual the thermostats and non contact Solid State Relay (S.S.R.) minimizes the temperature difference, reduces the noise and trouble shooting considerably.
- Six heaters are adjustable as rear/front position so as to handle any fabrics or interlinings.
- Anti-puckering silicon rubberized rollers are precisely controlled by air cylinder so that any different fabrics or interlinings can be perfectly fused and sandwich-fusing is also possible.
- Special alumite treated heating elements assure long service life and the heating-up period is short to reach 180°C.
- Easy to operate. Little maintenance.
- The change of belts can be done in a short time.

### 特長

- 連續式設備，提高生產量，且裁片長度不受限制。
- 採用自動蛇行修正裝置，上下皮帶經常保持固定位置。
- 採用雙重電子溫度控制器和無接觸斷電器 (SOLID STATE NON CONTACT RELAY) 故溫差減至最低程度並大大減少電子故障率及噪音。
- 六組電熱器可以前後 / 上下調整，故可適用各種布料及內襯。
- 特殊防皺矽膠滾筒，經由空壓調整，不但可適用各種布料並可內外雙層粘襯。
- 特殊鋁合金 (Alumite) 製成的電熱管，經久耐用在最短時間內可加熱至 180°C。
- 操作容易，維護簡單，更換皮帶簡易。

### Specifications

Mode 型號	LN-600R	LN-600S	LN-900R	LN-900S
Length 長	2,800mm	3,500mm	2,800mm	3,500mm
Width 寬	1,190mm		1,490mm	
Height 高	1,100mm			
Net Weight 機體重量	380kgs	400kgs	450kgs	470kgs
Fusing Width 壓片寬度	610mm (24")		910mm (36")	
Max. Pressure 最大壓力	5.0kgs/cm <sup>2</sup>			
Max. Temperature 最高溫度	200°C			
Power Supply 供電	220V or 380V 50/60Hz Single or 3 phase (單或三相)			
Heater 電熱	7.2kw		9.0kw	
Motor 馬達	180w		360w	

Design 結構圖 LN-900S

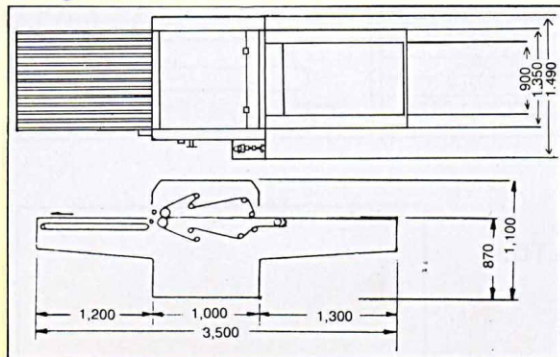

Design 結構圖 LN-600R

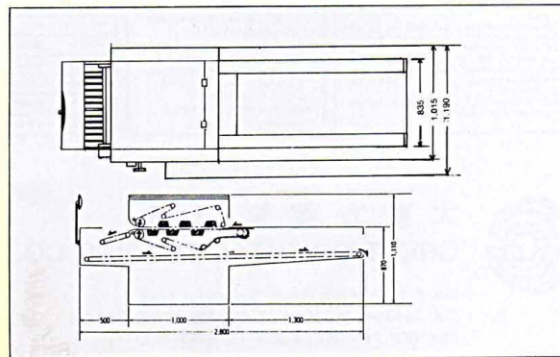

總公司Head office :  
立欣針車實業有限公司  
LUNA INDUSTRIAL CO., LTD.  
臺灣22061新北市板橋區四川路2段16巷9號5樓  
5F., No.9, Ln. 16, Sec. 2, Sichuan Rd., Banqiao Dist.,  
New Taipei City 22061, Taiwan  
(LEADER INDUSTRIAL AREA)  
TEL : 886-2-8966-5577 FAX : 886-2-8966-5443  
E-MAIL : info@lunasew.com  
luna0510@ms13.hinet.net  
HTTP : //www.lunasew.com

服務處Factory :  
立欣(寧波)針車有限公司  
LUNA (NINGBO) SEWING MACHINE CO., LTD.  
中國浙江省寧波市鄞州區姜山鎮星火科技園區環鎮北路13號  
No. 13 HuanZhen (N)Road, JiangShan Town  
XingHuo Scientific & Technical Area  
Yin Zhou District Ningbo City, China  
TEL : 86-574-8845-3458 8845-3468  
FAX : 86-574-8845-3478  
E-MAIL : lunaningbo@lunasew.com





# LUNAPRESS®

**LN-600B  
LN-600BN  
LN-600BNS**

## 氣壓全自動連續式粘襪機 STRAIGHT CONVEYOR TYPE



LN-600B  
Straight Conveyor Type  
LN-600BN  
Return Type  
LN-600BNS  
Straight & Return Type  
LN-600S  
Straight Conveyor Type

STACKER  
(OPTIONAL)  
**LN-06**

### Design 結構圖

#### LN-600B

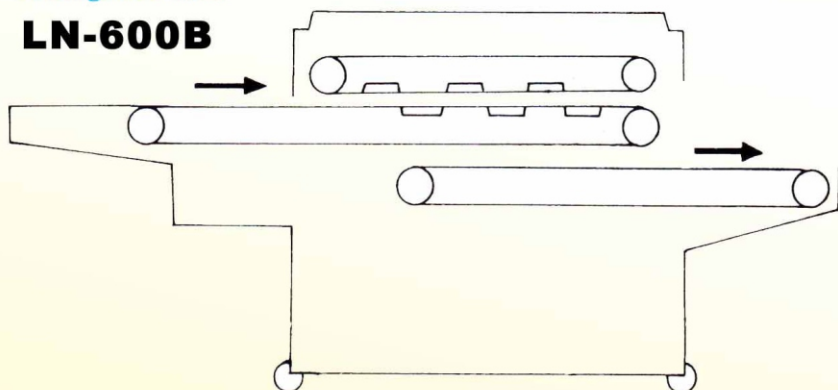

#### LN-600BN

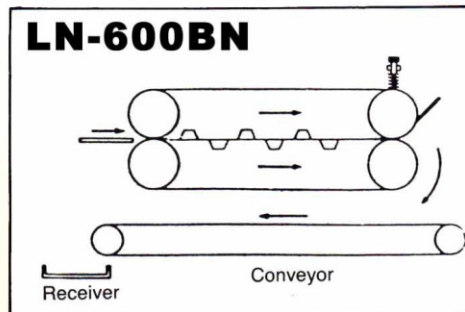

### Features

- This is continuous type machine therefore production is greatly increased.
- The temperature difference's range is kept at  $\pm 3^{\circ}\text{C}$  by using electronic thermostat and non-contact SSR's electronic parts.
- Silicon rubberized presser roller is used to ensure strong uniform pressure.
- The hard alumite heating elements assure long service life.
- Can be heated up  $180^{\circ}\text{C}$  in a short period of time.
- The entrance of the feed in point can be adjusted according to the thickness of the material and interlining being used, thus this machine can also be used to create any types of pockets, flaps, sleeve plackets etc.
- The pressure is easily adjusted by turning the thumb knob.
- Belt cleaning device is equipped so that the maintenance is simple.

### 特長

- 連續式設備，故可提高生產量。
- 採用電子溫度控制器和無接點斷電器(SSR)，故溫度差可上下保持 $3^{\circ}\text{C}$ 以內。
- 採用特殊矽膠滾筒，壓力均勻，故可燙出平整產品。
- 特殊鋁合金製成的電熱管，經久耐用且在最短時間內可加熱至 $180^{\circ}\text{C}$ 。
- 給料入口可根據材料之厚薄及襯裡之使用加以調整，因此該機器亦可用於任何口袋、袖口等之打褶。
- 壓力可適意調整。
- 附有皮帶污垢清潔裝置，維護簡單。

### Specifications

### 規格

Model	型號	CP-600B	CP-600BN
Motor	馬達	60W	
Max. Temperature	最高溫度	200°C	
Max. Pressure	最大壓力	3.5kgs/cm <sup>2</sup>	
Heater	電熱	6.0KW (6Pcs)	
Power Supply	供電	220V or 380V 50/60Hz Single or 3 Phases	
Net Weight	機體淨重	220kgs	
Gross Weight	機體毛重	380kgs	
Fusing Width	使用寬度	550mm	
Dimensions	機體尺寸	178(L) x 103(W) x 114(H) cm	
Packing Volume	裝箱尺寸	115(W) x 220(L) x 130(H) cm	

總公司Head office :  
立欣針車實業有限公司  
LUNA INDUSTRIAL CO., LTD.  
臺灣22061新北市板橋區四川路2段16巷9號5樓  
5F., No.9, Ln. 16, Sec. 2, Sichuan Rd., Banqiao Dist.,  
New Taipei City 22061, Taiwan  
(LEADER INDUSTRIAL AREA)  
TEL : 886-2-8966-5577 FAX : 886-2-8966-5443  
E-MAIL : info@lunasew.com  
luna0510@ms13.hinet.net  
HTTP : //www.lunasew.com

服務處Factory :  
立欣(寧波)針車有限公司  
LUNA (NINGBO) SEWING MACHINE CO., LTD.  
中國浙江省寧波市鄞州區姜山鎮星火科技園區環鎮北路13號  
No. 13 HuanZhen (N)Road, JiangShan Town  
XingHuo Scientific & Technical Area  
Yin Zhou District Ningbo City, China  
TEL : 86-574-8845-3458 8845-3468  
FAX : 86-574-8845-3478  
E-MAIL : lunaningbo@lunasew.com

